

# User manual easyfoam365+ foam and disinfectant units ST-164.

## Product Nr.: 200 164 ...

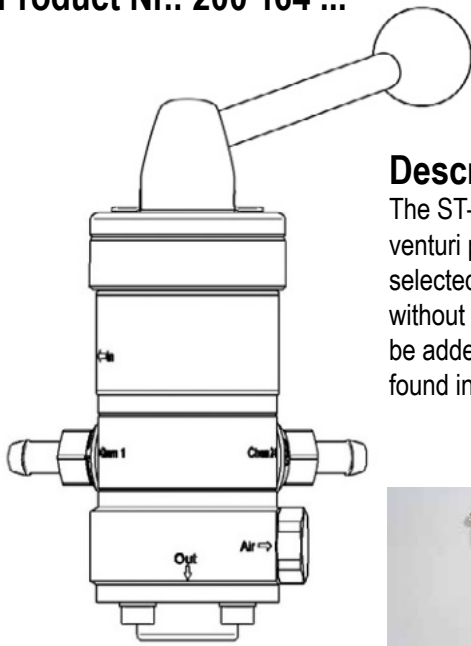

The choice of perfection



### Description

The ST-164 is an injector unit for admixing liquid detergent concentrates with water using the venturi principle. Via a selector lever (see photos below) two alternative detergents can be selected for admixing. A third selector lever position makes it possible to flush the unit clear without any detergent intake. Via an optional compressed air connection compressed air can be added to the detergent/water mixture. Any accessory components needed for this can be found in the spare parts drawing at the end of these Operating Instructions.

### Selector lever switching positions



Rinsing



Detergent 1



Detergent 2

### Safety



#### Hazard

If these instructions are not followed there is a danger of physical injury, danger to life and material damage!



Please comply with the Operating Instructions! Incorrect operation can lead to serious injury. Read the Operating Instructions before you use the appliance.



### General safety notes

- To guarantee safe operation the injector unit may only be used in accordance with these Operating Instructions.
- Keep these Operating Instructions in a safe place for later reference.
- Please also observe the safety instructions for the detergent and if applicable of the high pressure cleaner manufacturer.
- Do not mix detergents one with the other.
- Wear suitable protective clothing and gloves when working.
- Never direct the high pressure jet at persons or other living creatures.
- Read the safety data sheets and observe the corresponding safety and handling regulations.



**Info** In addition the required safety and legal regulations for the respective type of use must be observed. This also applies to all accessories used.



### Intended Use

- The ST-164 injector unit is designed for admixture of detergents with water and for straightforward rinsing with water.
- Only Pressure Equipment Directive (PED) Group 2 liquids may be used as media. In case of doubt contact the equipment manufacturer.
- The unit may only be used with a suitable pressure generator.
- The unit is not designed for use with persons (children included) with restricted sensory and mental capabilities due to lack of experience and/or lack of knowledge unless they are supervised by a person responsible for their safety or if they have received instruction from that person in use of the equipment.
- In general children are forbidden to use this equipment.



Connection lines used and the ST-164 injector unit itself must be flushed clear for 20 seconds prior to any change of detergent. In the case of very powerful detergents please contact the manufacturer who can then assess whether operation with this unit is possible. Any form of operation of the ST-164 injector unit over and above is deemed impermissible.



### Qualified personnel

The bypass injector may only be installed by qualified personnel able to operate the bypass injector properly. Qualified personnel are persons familiar with installation, commissioning and decommissioning, operation, maintenance and repair and who hold a qualification appropriate to their work.

# User manual easyfoam365+ foam and disinfectant units ST-164.

Product Nr.: 200 164 ...



The choice of perfection

## Commissioning

The injector ST-164 may be secured either with the optionally available wall bracket or with a panel design fitment. Position detergent canisters in the vicinity of the injector unit. They should be no more than 3 m distant from the injector unit.

Select the appropriate dosage nozzles.

Connect the intake suction hoses for the detergent to the ST-164 detergent connectors.



Do not confuse hoses and canisters!

Connect a suitable hose to the injector unit outlet.

Connect a suitable spray attachment.

Connect the injector unit to the pressure generator.

Set the injector unit to clear flush (selector lever in the intermediate position).

Check all connections.

## Securing with wall bracket

Assembly set for wall mounting (product Nr.: 20 0168 420)

Pos.	Item number	Description
1	00 0005 094	Adapter wall bracket
2	00 0005 085	Wall bracket
3	04 0004 180	Hexagon Screw M8 x 45
4	04 0004 175	Plate M8

## Panel mounting

Place the ST-164 as shown in the panel mounting bracket plate.

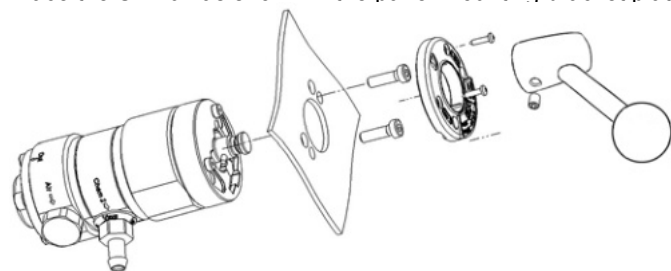

For ST-164 not necessary

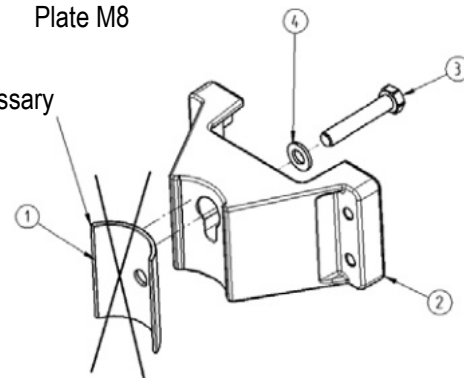

## Template with panel mounting hole pattern

You can overlay this matching template (see page 8)

on the bracket plate provided and then

drill the holes as illustrated.

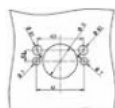

Please note that the maximum mounting

plate thickness of 3 mm must not be exceeded.

## Adjusting the dosage rate

Table reading example for dosage nozzle

Flow volume: 15 l/min

Detergent or disinfectant

concentration: 5 %

Calculated in accordance

with the following data:

$$(5 \% * 15 \text{ l/min}) / 100 \% = 0,75 \text{ l/min}$$

(dosage rate)

=> nozzle selection 1,2

(read from diagram)

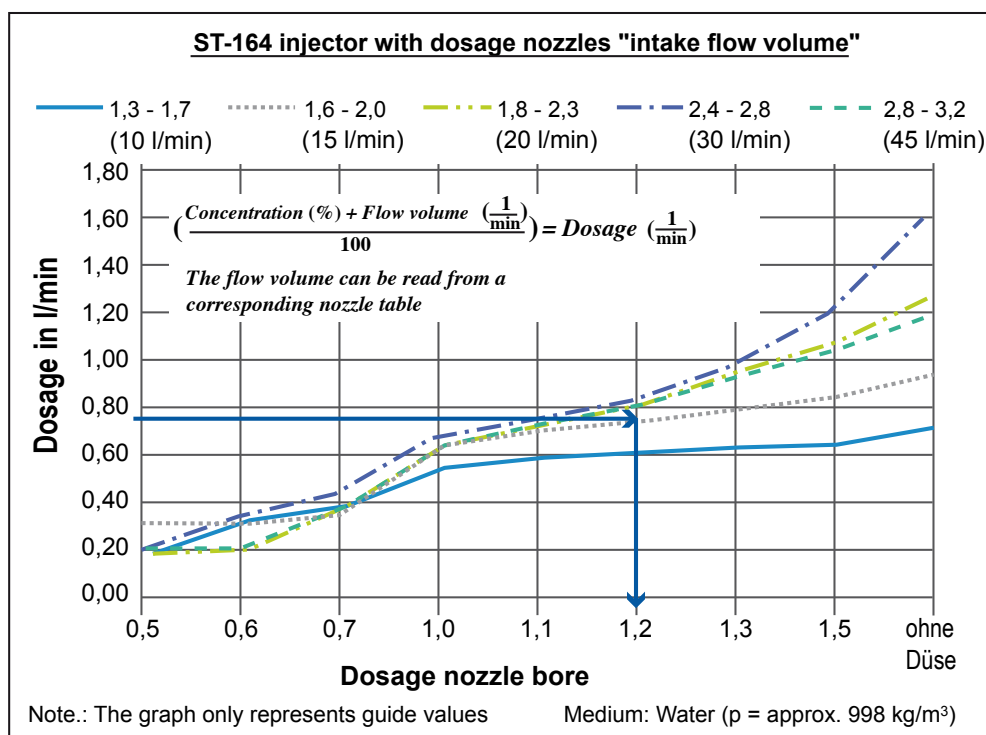

# User manual easyfoam365+ foam and disinfectant units ST-164.

Product Nr.: 200 164 ...



The choice of perfection

## Sample reading from graph

(for this the optional ST-161 dosage valve is needed)

Flow volume: 15 l/min

Detergent or disinfectant concentration: 3 %

Calculated in accordance with the following formula:

$$(3 \% * 15 \text{ l/min}) / 100 \% = 0,45 \text{ l/min}$$

(dosage rate)

=> **graph setting 2**

(read from diagram)

ST-164 injector nozzles are interchangeable. By suitable nozzle selection it is possible to adjust the injectors to match virtually all feasible applications.

The choice of injector nozzle combination influences definitively the quantity of maximum detergent induces under suction (concentration) and resistance of the injector to pressure losses caused by the accessories (hoses, spray attachment etc.)

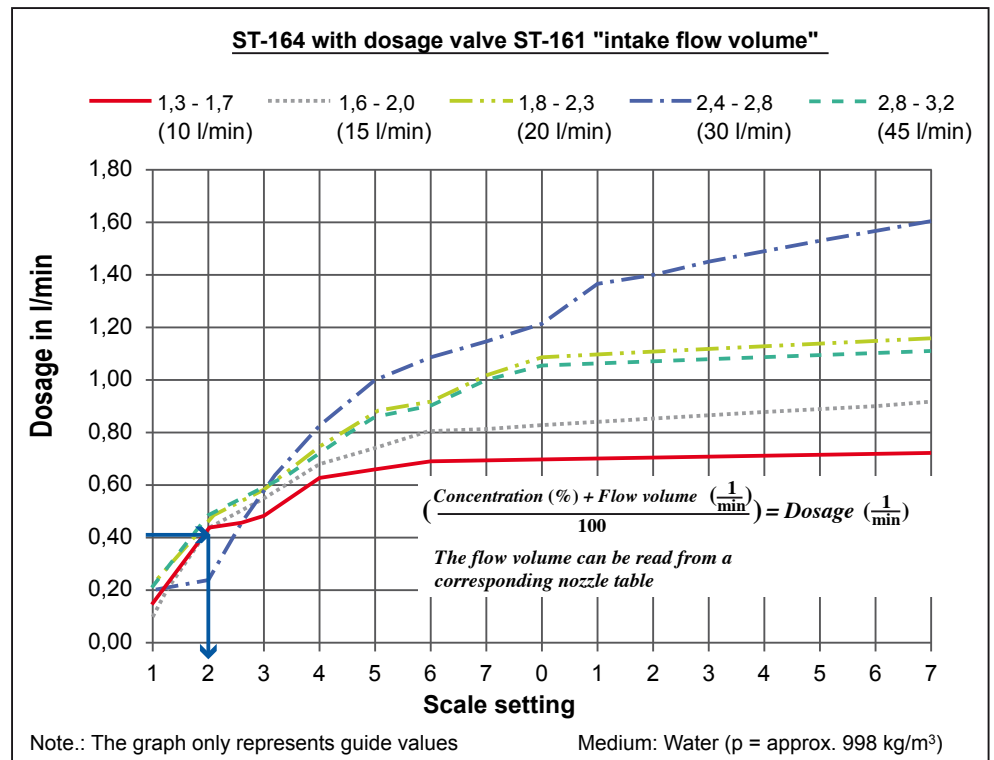

Each injector consists of two nozzles - the injector nozzle itself and the counter nozzle.

Counter nozzle



Injector nozzle



## Changing injector nozzle and diffusor nozzle



Carry out work on the injector unit clean surroundings. Use suitable tools. Please be careful not to lose small parts. The 4 screws (Pos. 1) must be tightened with a torque of 13,0 Nm.

Tool for changing a counter nozzle:

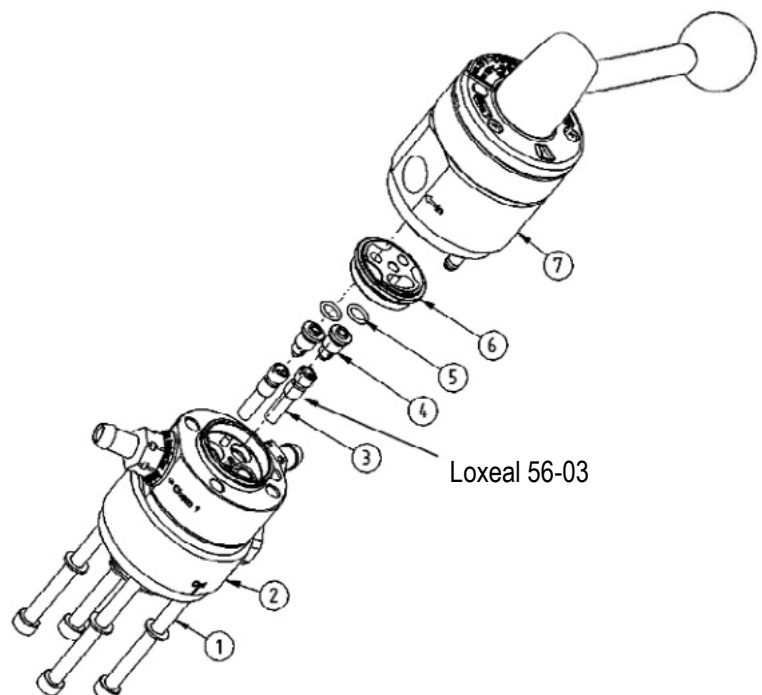
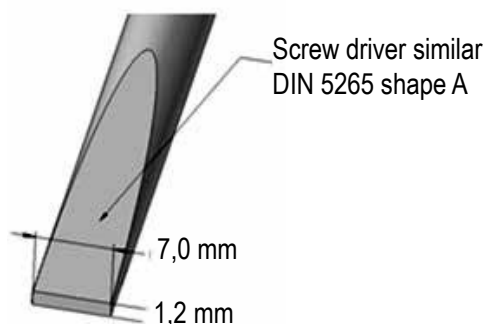

## Overview injector nozzles - counter nozzles ST-164

Injektordüse / Injector nozzle	Gegendüse / Counter nozzle
04 0003 534 (ø 1,2 mm)	04 0003 517 (ø 1,7 mm)
04 0003 535 (ø 1,3 mm)	
04 0003 536 (ø 1,4 mm)	
04 0003 537 (ø 1,5 mm)	04 0003 521 (ø 2,0 mm)
04 0003 538 (ø 1,6 mm)	
04 0003 539 (ø 1,7 mm)	
04 0003 541 (ø 1,8 mm)	04 0003 523 (ø 2,3 mm)
04 0003 542 (ø 1,9 mm)	
04 0003 543 (ø 2,0 mm)	
04 0003 544 (ø 2,1 mm)	
04 0003 546 (ø 2,2 mm)	04 0003 528 (ø 2,8 mm)
04 0003 547 (ø 2,3 mm)	
04 0003 548 (ø 2,4 mm)	
04 0003 531 (ø 2,5 mm)	
04 0003 549 (ø 2,8 mm)	04 0003 532 (ø 3,2 mm)

Most applications can be covered by standard combinations pre-tailored in consultation with us:

**For high pressure applications of 80 bar and above we recommend:**

Combination	Unit
1,3 – 1,7	10 – 15 litres
1,6 – 2,0	15 – 20 litres
1,8 – 2,3	20 – 25 litres
2,4 – 2,8	> 25 litres

**For low-pressure applications we recommend:**

Combination	Unit
2,1 – 2,8	25 bar + compressed air
2,4 – 2,8	< 25 bar

### Counter-pressure diagram ST-164

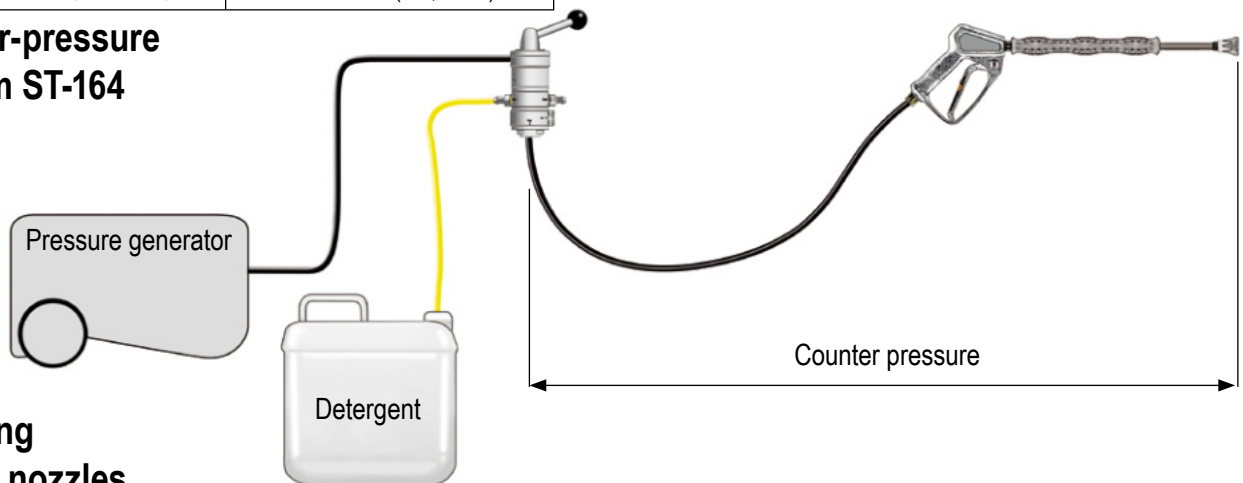

### Changing dosage nozzles

Dosage nozzles make it possible to restrict the intake suction flow volume or detergent concentrate from both detergent connectors (Chem 1 and Chem2) so as to adjust the concentration of detergent in the water. You can obtain a basic dosage nozzle set (restrictors) under the following product code: 20 0163 340 Restriction Bag ST-163

- Remove the intake hose.
- Withdraw the old dosage nozzle from the induction socket.
- Insert the new dosage nozzle into the induction socket.

For choice of dosage nozzles see „Dosage Adjustment“ Chapter



There is an o-ring for each dosage nozzle. During assembly please ensure that the o-rings are not damaged.

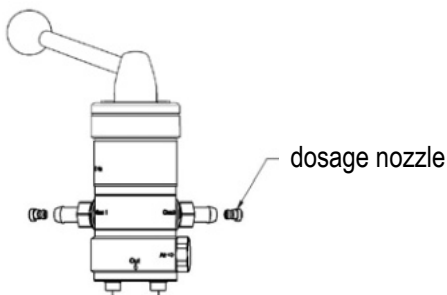

Higher diffusor-pressure tolerance means that pressure losses caused by fittings, hoses, sprayguns etc. may also be higher. Diffusor-pressure tolerance reflects the maximum diffusor-pressure level at which injector induction suction continues.

### Injector nozzle to large counter nozzle => high intake level and low counter-pressure tolerance

Example:

Input pressure 100 bar, injector nozzle 1.3 and counternozzle 2.8 => 2 litres induction level and diffusor-pressure tolerance 27 bar

### Injector nozzle to small counter nozzle => low induction level and higher counter-pressure tolerance

Example:

Input pressure 100 bar, injector nozzle 1.3 and counter nozzle 1.7 => 0.5 litre induction level and diffusor-pressure tolerance 52 bars

All details are approximate values only.

# User manual easyfoam365+ foam and disinfectant units ST-164.

Product Nr.: 200 164 ...



The choice of perfection

## ST-164 operating modes

### Operating mode 1: Operation without compressed air

The ST-164 injector unit can be used simply as a cleaning medium injector (preferably at high pressure).

Here the injector unit is incorporated in the water supply downstream of the pressure generator.

**Figure 1a:** Selection between two alternative detergents and a clear flush position can be made via the selector lever.

**Figure 1b:** At pressures > 70 bar foaming detergents can be foamed effectively with an air injector using a separate foam lance with an air injector. Available foam lances are for example the ST-72, ST-74 and ST-75.

### Assembly scheme: Use with detergent (Figure 1a)

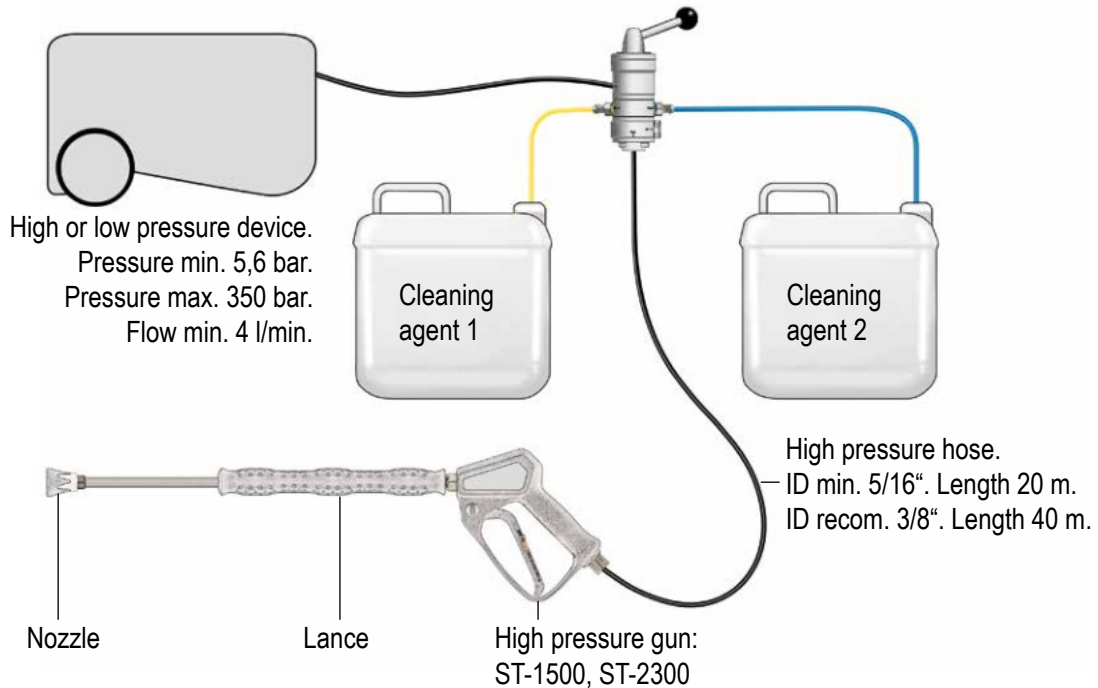

### Assembly scheme: Use with foaming agent (Figure 1b)

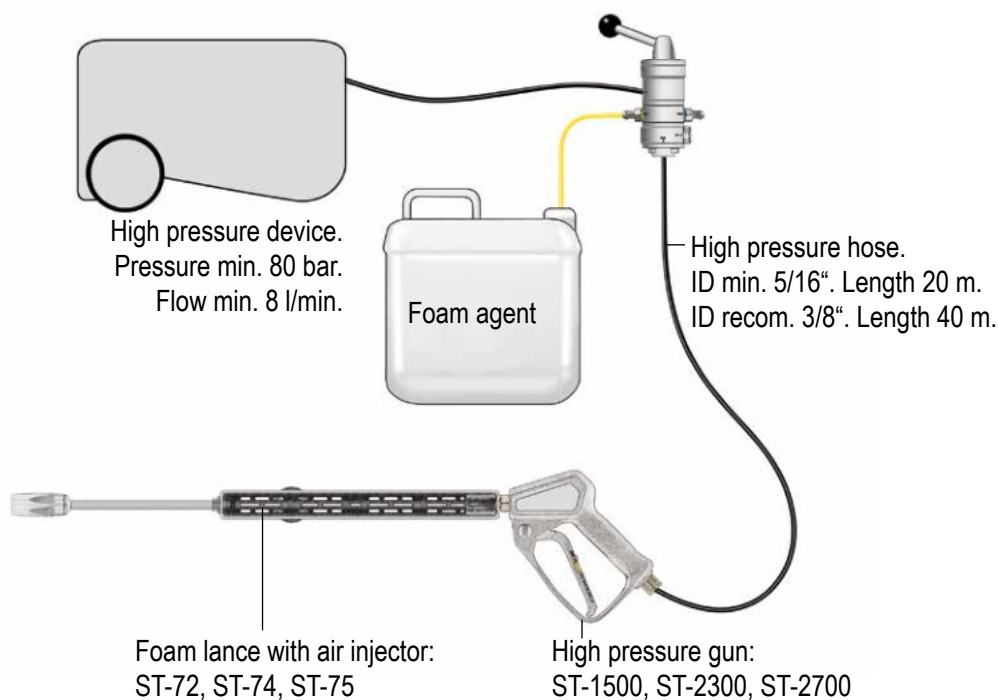

**User manual easyfoam365+  
foam and disinfectant units ST-164.  
Product Nr.: 200 164 ...**

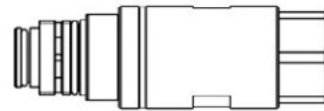

ST-164 check valve  
(Product Code 200 164 370)



The choice of perfection

**Operating Mode 2: Operation with compressed air**

To install the ST-164 check valve you must first unscrew the blanking plug with o-ring from the ST-164 injector unit (Diagram 1). The ST-164 check valve is then screwed in (Diagram 2). Compressed air can then be connected to the ST-164 check valve.

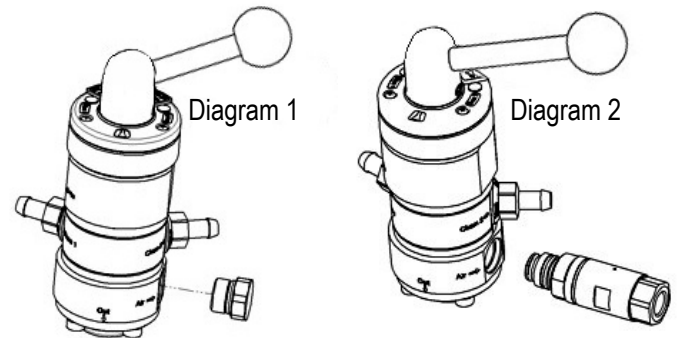

Foaming with compressed air is particularly suited to generating foam at low water pressures: 3-70 bar

**Assembly scheme with detergent**

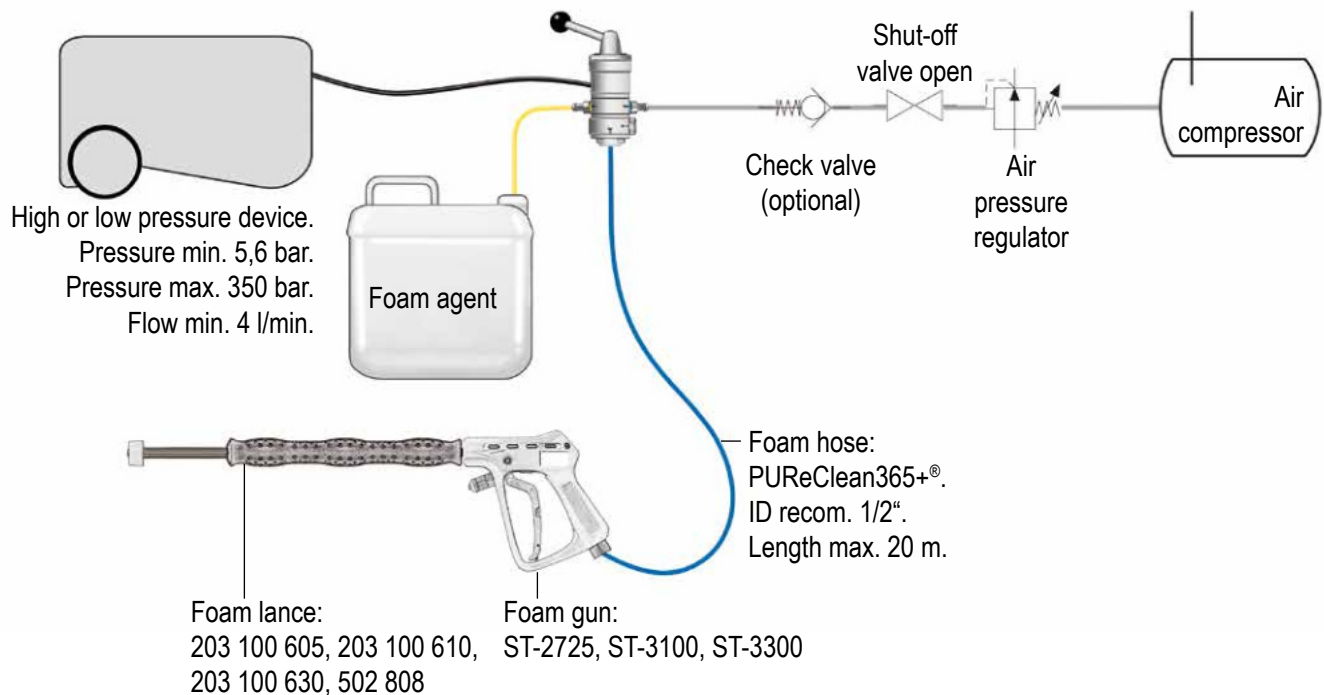

**Troubleshooting**

Injector does not suck in foaming agent or detergent from the container or no foam is generated:

**ST-164 without compressed air**

- Dosage nozzle blocked: clear nozzle with thin wire as necessary. If strongly scaled select new dosage nozzle
- Selector lever in wrong position
- Intake suction hose damaged
- Intake suction hose not immersed in foaming agent
- High pressure hose too long /nominal bore to small (minimum bore 8)
- Foam lance used without injector => select foam lance with injector
- Check non-return valve whether piston operates smoothly or shows signs of damage, replace as necessary
- Foam lance nozzle too small => select lance with larger air injector nozzle

**ST-164 with compressed air**

- Dosage nozzle blocked - clear nozzle with thin wire as necessary. If strongly scaled select new dosage nozzle
- Selector lever in wrong position
- Intake suction hose damaged
- Intake suction hose not immersed in foaming agent
- Air connection not correct or not connected in the first place
- Compressed air line shut-off valve closed
- Connection of a pressure reducer in the compressed air line (2 – 6 bar)
- High pressure hose too long /nominal bore to small (minimum bore 12)
- Foam lance used with air injector
- Check non-return valve whether piston operates smoothly or shows signs of damage, replace as necessary
- Equipment with too small cross-sections used

# User manual easyfoam365+ foam and disinfectant units ST-164.

Product Nr.: 200 164 ...



The choice of perfection

## Spares

Below is a list of individual ST-164 parts:

Please note: It is only allowed to use original, high strength screws.

Pos.	Item-No.	Description
1	040 004 165	Headless screw
2	040 000 631	Pan head screw
3	200 163 360	Check valve Peek
4*4	040 004 161	Screw M6x70
5*4	040 002 536	Retaining washer VS-6
6	040 004 206	Screw
7*2	050 002 458	O-Ring 4x1 EPDM 80 shore
8	040 004 827	Control channel
9	020 001 183	Blind Plug yellow
10	020 001 182	Blind Plug blue
11	040 004 170	Bolt
12	040 00 4152	Screw M6x20
13	040 003 525	Cover
14	040 003 545	Piston
15	040 003 540	Distance ring
16	040 004 825	Turning device
17	040 004 822	Upper part
18	040 001 720	Pressure disc
19*1	050 002 340	O-Ring 27x1,5 EPDM 80 shore
20	050 002 315	O-Ring 23x1,5 viton
21	050 002 310	O-Ring 19x1,5 viton
22	050 002 322	PTFE Slide seal ring
23	040 004 823	Middle part
24*1	050 002 345	O-Ring 30x1,5 EPDM 80 shore
25	020 005 086	Cap ST-164
26	020 005 089	Notch
27	060 001 180	Spring bolt
28	020 005 087	Cover ST-164
29	040 004 820	Lever holder
30	040 003 530	Lever
31	020 005 115	Ball handle
32	040 000 060	Pin 5x20
33*1	050 000 385	O-ring 13x1,5 FEPM 90 shore
34*1	020 005 088	Peek disc
35	040 004 828	Blind plug
36	050 000 435	O-Ring
37	020 005 100	Cover blue
38	020 005 105	Cover yellow
39	040 003 523	Nozzle 2,3
40	040 003 535	Injector nozzle
41*2	050 002 302	O-Ring 7x1,5 FEPM 90 shore
42	200 044 490	Ball bearing
43	040 004 824	Base part

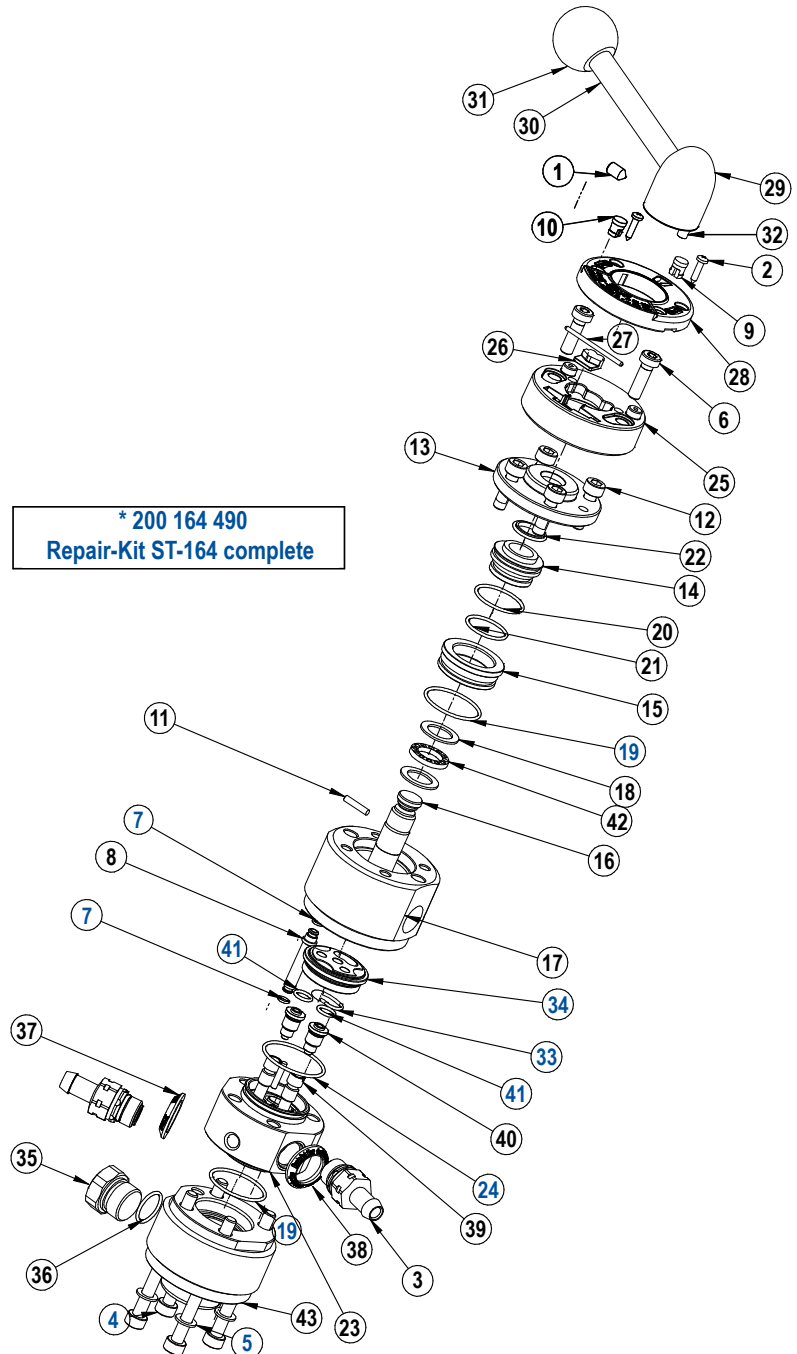

## Disposal

Please dispose of old unit in an environmentally friendly manner. Old units contain valuable recycling materials which should be forwarded to a recycling facility. Please dispose of old units therefore via appropriate collection points.

### Template with panel mounting hole pattern

You can overlay this matching template on the bracket plate provided and then drill the holes as illustrated.

